

Liquid Mass Flow Meter Instruction Manual

LM-3000L Series

Safety precautions

⚠️ WARNING Incorrect handling may cause death or injury.

- Before connecting the fittings, check that no damage or defects are found on the fittings. Make connect properly and make sure that leak test is conducted before actual operation to prevent fluid from leaking into the atmosphere (Hereafter, the measured fluid is called "liquid" or "fluid").
- DO NOT** apply any fluids corrosive to the wetted materials. Corrosion may cause fluid to leak into the atmosphere. Check the liquid type to be used in advance.
- The device is not designed as an explosion-proof structure. **DO NOT** use device in a where explosion-proof structures are required. Doing so may cause fire or explosion.

⚠️ CAUTION Incorrect handling may lead to medium or slight injury or may cause damage to, or loss of, facilities or equipment.

- Observe the precautions listed in the **WARNING** (above)
- Strictly observe the electrical specifications. Not doing so cause fire, damage to sensors or malfunction.
- This device is not designed to be waterproof. **DO NOT** locate this device outdoors or in a place where it may be splashed with water. Doing so may cause fire, trouble or malfunction of this device.
- DO NOT** modify this device. It may cause fire or other problems.
- While a power supply is applied to the device, +15VDC and -15VDC must be applied simultaneously. If only +15VDC or -15VDC is applied, electronic circuits will become unstable and it may cause a malfunction.
- This device is not designed to handle hot swap. Please avoid attaching and removing the power supply connector and interface connector with the power switched on. Attachment and/or removal with the power on may result in failure of the device.
- This device is a precious device, please handle it carefully. Dropping down or handling it carelessly will cause damage. Please use assist instrument while moving or setting the device.
- Regular maintenance is recommended for continuous use of this device (Recommended frequency is once a year).

1. Introduction

This manual explains basic operation of the Liquid Mass Flow Meter LM-3000L Series (Hereafter, it is called "LM"). Please read through this manual and the separate volume "The Digital Interface Manual" carefully to become familiar with the features of this device.

2. Summary

The liquid mass flow meter LM is a flow meter which can accurately measure mass flow rate of liquids. By connecting with vaporizer (VU series) and external valve (Solenoid valve CV series or Piezo valve PV series), a high-performance mass flow control/ vaporization system could be formed to meet various needs.

3. Features

The LM has the following features.

- LINTEC's original ambient temperature compensation mass flow sensor is incorporated for measuring flow rates.
 - Low sensor temperature, long-time steady monitor, and few problems such as degradation of gas to be monitored.
 - The effect of ambient temperature is less because the sensor temperature is kept at the ambient temperature.
 - Steady temperature distribution of sensor and high-speed response.
- Digital control by microprocessor and high-resolution A/D, D/A converter;
 - High functionality
 - By setting of device number (address), multiple devices can be controlled through a single interface
 - Many added functions such as flow totalizer, auto-zero, and ramping function etc.
- Universal digital interface
- Superior corrosion resistant sealing materials make maintenance easy. Metal seals (Stainless Steel 316L) are used
- Particle free structure
- By using a metal case and various types of filters, steady operation can be achieved even in an environment of high-frequency noise and stationary magnetic field
- RoHS compliant
- Bypass-less construction (Easy liquid feed and internal purging, mounting direction: free)

4. Specification/Dimensions

(1) Specification

| Product name | Liquid Mass Flow Meter | | |
|---|--|--------------------------------|-----------------------------|
| | LM-3102L/3112L | LM-3202L/3212L | LM-3412L |
| Model | LM-3102L/3112L | LM-3202L/3212L | LM-3412L |
| Precursor type and Fluid & flow rate (except HCl, HF and other liquids which corrode stainless steel) | C2H5OH 0.1 to 1.0g/min F.S. | C2H5OH 1.0 to 6.0g/min F.S. | C2H5OH to 20g/min F.S. |
| | H2O 0.1 to 0.2g/min F.S. | H2O 0.2 to 1.0g/min F.S. | H2O 2.0 to 5.0g/min F.S. |
| Operation of external valve | LM-3*02L : Piezo actuator LM-3*12L : Solenoid actuator | | |
| Surface treatment | NN: No treatment (no surface treatment) MN: Precision polishing | | |
| Minimum control flow rate | 10% F.S. | | |

| | | |
|--|---|---------------|
| Analog flow rate setting signal | 0 to 5VDC (Proportional to flow rate) | |
| Analog flow rate output signal | 0 to 5VDC (Proportional to flow rate) | |
| Accuracy (Note1) | ±1.0 %F.S. | ±2.5 %F.S. |
| Repeatability (Note1) | ±0.5 %F.S. | |
| Operating differential pressure (Note1) | 50 to 300 kPa(D) | |
| Maximum operating pressure (Note1) | 300 kPa(G) | |
| Pressure Limit | 1MPa(G) | |
| Operating temperature & Humidity (Note2) | 15 to 35 °C/0 to 80 %RH (Condensation should be avoided) | |
| Temp. coefficient (Note2) (Reference Temp.25) | Zero | ±0.1 %F.S./°C |
| | Span | |
| Leak integrity | Less than 1×10^{-11} Pa·m ³ /sec (He) | |
| Recommended gas for pushing the liquid (Note3) | He | |
| Storage temperature & Humidity | 0 to 60 °C/0 to 80 %RH (Condensation should be avoided) | |
| Mounting direction | Free | |
| Wetted materials | Stainless Steel 316L | |
| Seal materials | Au | |
| Fittings | 3.2mm VCR(male), 6.35mm VCR(male), 3.2mm SWL | |
| Digital interface connector | RS-485 (RJ45 modular jack) 2-wire system | |
| Power supply | LM-3*02L: +15VDC±3% 100mA, -15VDC±3% 50mA LM-3*12L: +15VDC±3% 150mA, -15VDC±3% 200mA | |
| Inrush current (Actual measurement value) | +15V: 11A 130µs -15V: 9A 110µs | |
| Analog interface connector | D-sub connector (Lock screw M3) | |
| External valve connector | HIROSE HR10 connection LM-3*02L: 6Pin LM-3*12L: 4Pin | |
| Weights | Approx. 800g | Approx. 1kg |

Note 1) If it is used as a liquid controller for the vaporization system, it will be described in the specification of the vaporization system.

Note 2) The flow rate will be not accurate if the liquid temperature is different from surrounding temperature when measuring or controlling, please set the same temperature for liquid and the device.

Note 3) There is the possibility of failure about measuring and controlling. To reduce the gas solubility of the liquid, Helium (He) is recommended to be the pressurized gas.

- Connect the LM to the frame ground.
- Flow rate calibration is done by one type of liquid (C2H5OH or H2O). The liquid to be used should be specified in advance.
- Liquid with solid materials can't be controlled.
- If the mixture ratio of mixture liquid is changed, please consult us in advance.
- If there are particles in the target liquid, install a filter to remove particles more than 0.2µm on the primary side (the inlet side).
- The viscosity of liquid controlled by the LM should be less than 0.1Pa's (100cp). Please consult us if the viscosity of liquid is high.
- Please feed in the liquid after completely purging (Recommended).

(2) Dimensions

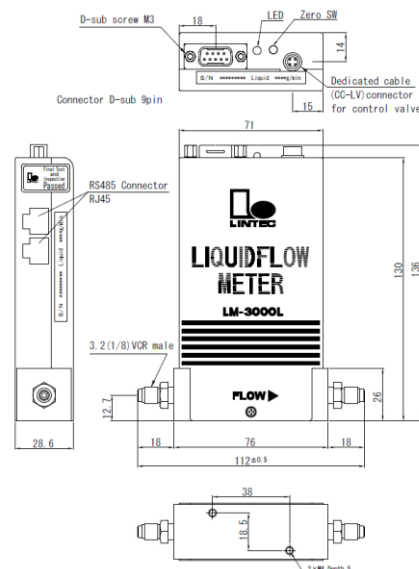

5. Ordering Information

LM - 3**2L - MN - 22 VR1 J A0A0

[1] [2] [3] [4] [5] [6]

- Series Model
LM: Liquid Mass Flow Meter Series
3*02L: Piezo actuator, 3*12L: Solenoid actuator
- Seal type (Surface treatment)
NN: Stainless Steel 316L (No treatment)
MN: Stainless Steel 316L (Precision polishing treatment)
- INLET, OUTLET fitting size (IN side, OUT side)
E.g. IN : 3.2mm, OUT: 3.2mm, label as [22] 2 indicates size is 3.2mm
- Fitting type
VR1: VCR-compatible 112mm SWL: SWL127.4 mm PW3: 1.125"W seal 92mm
- Option J: 2% Close (This option "J" is recommended)
- Other options
Non-option setting is labeled "AA0A0", please consult for more information.

6. Connection

(1) Analog interface connector

Mounted connector :D-Sub 9pin (male) Pair connector :D-Sub 9pin (female)
(Lock screw M3)

| Pin No. | Signal Name | Function |
|---------|--|---|
| 1 | Valve override open/close signal (Note4) | +15VDC: Open, -15VDC: Close |
| 2 | Flow rate output signal 0 to 5 VDC | Flow rate of power output (plus side) 0 to 5 VDC |
| 3 | Power supply +15VDC±3% (Note 6) | Power supply (plus)100mA /150mA |
| 4 | Power supply COMMON (Note 5) | Power supply COMMON ±15VDC |
| 5 | Power supply -15VDC±3% (Note 6) | Power supply (minus) 50mA/200mA |
| 6 | (Flow rate setting signal 0 to 5 VDC) | (Flow rate of power input (plus side) 0 to 5VDC) |
| 7 | Flow rate output COMMON (Note 5) | Flow rate output signal COMMON |
| 8 | Flow rate setting COMMON (Note 5) | (Flow rate setting signal COMMON) |
| 9 | N.C. | - |

Note4) The impedance of the input setting of flow rate voltage is 100kΩ, the resistance of valve open and close is 100kΩ.

Note5) Pin No. 4,7,8 are connected in this device.

Note6) The current value (connect with external valve) will be different depending on the model.

Please refer to item 4 (1) specification.

() refers to connect with an external valve.

To avoid the effect of COMMON potential difference, please follow the circuit as below.

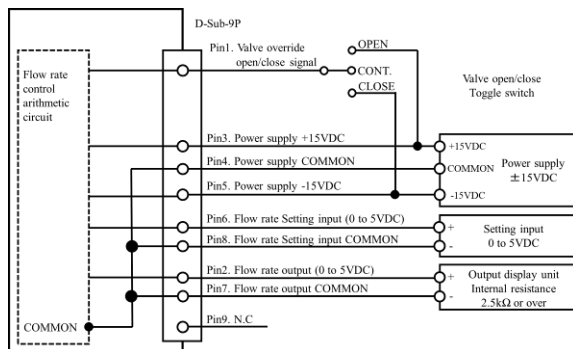

If the high accuracy of the control is necessary, setting flow rate voltage is COMMON (Pin.8), and the flow rate output is COMMON (Pin.7) on the power side. Please do not connect the power COMMON (Pin4).

(2) Digital interface connector

Mounted connector: RJ45 modular jack Pair connector: RJ45 modular plug

| Pin No. | Name | Function |
|---------|-------------------|--|
| 1 | Signal COMMON | RS-485 Signal COMMON |
| 2 | Signal COMMON | RS-485 Signal COMMON |
| 3 | N.C. | - |
| 4 | Signal [-Txd/Rxd] | RS-485 2-wire system transmitter. receiver minus signal |
| 5 | Signal [+Txd/Rxd] | RS-485 2-wire system transmitter. receiver plus signal |
| 6 | N.C. | - |
| 7 | N.C. | - |
| 8 | N.C. | - |

(3) External valve connectors

LM-3*12L: Mounted connector: HR-10-7R-4S(73) Pair connector: HR-10-7P-4P(73)

| Pin No. | Signal name | Pin No. | Signal name |
|---------|-----------------------------|---------|-------------|
| 1 | Valve cont. signal | 3 | N.C. |
| 2 | Valve cont. signal (-15VDC) | 4 | N.C. |

Cable: CC-LV-3-3M

LM-3*02L: Mounted connector: HR-10-7R-6S(73) Pair connector: HR-10-7P-6P(73)

| Pin No. | Signal name | Pin No. | Signal name | Pin No. | Signal name |
|---------|-----------------------------|---------|--------------------|---------|-------------|
| 1 | Valve cont. signal (120VDC) | 3 | N.C. | 5 | N.C. |
| 2 | N.C. | 4 | Valve cont. signal | 6 | N.C. |

Cable: CC-LV-4-1M

7. Alarm function

This LM features two alarm modes: alarm A and alarm B. Using a digital interface, alarm output of the digital connector or LED indicator located on top of the LM can monitor the alarm status. Alarm setting can only be changed through digital communication, so if a change is required, please do it through communication. Details are described in the digital interface manual and others.

| Alarm | Set off | LED indicator |
|--------|---------------------------------------|--|
| A | Setting value ≠ Flow rate output | Continuous Red |
| | Flow totalizer Alarm level 2 | |
| | Power supply voltage drop (+15VDC) | Off |
| B | Valve voltage offset (At controllers) | Red (every 0.5sec flashing) |
| | Zero adjustment error (Note7) | |
| | Flow totalizer Alarm level 1 | |
| Other | Command error | Continuous Red (every 0.5sec flashing) |
| Normal | - | Green (every 1sec flashing) |

8. Initial setting value (factory shipped value)

This device is provided with a software switch for operation mode setting. Before operation, input the necessary data for various functions by using the digital interface. Details of the functions are described in the digital interface manual etc.

| Software switch | Available values | Function | Default |
|-----------------|------------------|--------------------------|---------|
| Device number | 00 to 99 | LM No. Registration | 00 |
| Alarm A range | 1 to 99 [%] | Setting Alarm A range | 5% |
| Alarm B range | 1 to 99 [%] | Setting of Alarm B range | 20% |

| | | | |
|------------------------|--|---|---------------------------------|
| Alarm timer | 0 to 99 [seconds] | Setting of time to prohibit Alarm | 5 seconds |
| Alarm A output | Enable / Disable | Setting of Alarm A LED display | Enable |
| Alarm B output | Enable / Disable | Setting of Alarm B LED display | Disable (Note7) |
| Operation mode | Analog / Digital | Switching of Analog/digital | Analog |
| Power on mode | Analog / Preset | Switching of Operation mode in power turning on | Preset |
| Valve control | C / O / H / S | Close / Open / Hold / Servo | Servo |
| Control speed | FAST / SLOW | Switching of Response speed | FAST |
| Control mode (Note8) | 2%Close/2%Hold/Normal | Control mode setting at flow rate setting-2%. 2%Close: Valve Close 2%Hold: 2% Control Normal: Normal Control | 2%Close |
| Communication protocol | 9600 to 38400bps 8bit / 7bit Odd/Even/ None 1bit / 2bit | Baud rate Character length Parity Stop bit | 9600bps 7bit None 2bit |

Note7) Zero adjustment error alarms regardless of the "Enable" / "Disable" of the alarm.

Note8) This table is the setting when less than 2% Close setting "JA0A0" is specified.

• If the zero adjust button on the top of the device is pressed and held for over 5 seconds, the communication protocol is reset to default value (factory shipped value).

9. Operation

(1) Preparation, operation

- This product is packed in a clean room before shipment. Please break the seals in a clean room after taking it out of its box.
- Check the liquid type and flow rate, and check the direction of the gas flow and the MFC before installation.
- Check for gas leaks from the tubing with a helium (He) leak detector.
- Connect the interface connectors according to the Connector table.
- Power requirements are +15VDC:100mA(150 mA) and -15VDC:50mA(200 mA). Check the voltage, polarity and capacitance of the power supply voltage.
- Turn on the power supply and let the equipment warm up for at least 5 minutes (Recommended time: 30min).
- Adjust the zero point by pressing the zero adjustment, switch located on the top of the LM. **Before zero-point adjustment, check that gas is not being supplied and the device was warmed up for 30 minutes or more in order to ensure sensor stability.**
- Input the flow rate setting signal and supply gas with required differential pressure to the LM. The LM will begin to control the liquid flow in proportion to the preset voltage. Full-scale voltage is 5VDC. Maximum input voltage is ±15.5VDC.
- When the output flow rate signal is used, the tolerance voltage of the external device should be more than ±15.5VDC. When the power is supplied, there is the possibility to achieve the maximum voltage of ±15.5VDC.
- When a highly reactive liquid is used, thoroughly purge all foreign matter from the tubing and the LM before operation.
- When contaminated liquid is used, install a filter at the equipment inlet.
- Use the LM within the range of the operating temperature (Standard product: 15 to 35°C), and keep it at the same temperature with the gas. If used in any environment that does not meet the above-mentioned requirements, the flow rate cannot be measured accurately and the device may fail.
- Do not switch the power supply on and off within one second. It may cause failure.
- Helium (He) gas is recommended for pushing the liquid. If any other gas is used, the dissolved gas will produce bubbles, and it may make the control unstable.
- Bubbles may become the cause of the unstable control. So, perform the vacuuming of liquid line thoroughly before the introduction of liquid (Recommended).

(2) Usage of the digital interface

This unit supports RS-485 interface. Therefore, with the use of the digital interface, high performance liquid mass flow control can be achieved. Please refer to the digital interface manual.

10. Product warranty

(1) Period

This product is guaranteed for a period of 1 year from the date of shipment. Defects are repaired according to the following regulations.

(2) Scope

Warranty coverage is restricted to this product only. Any other damage caused by this product is not covered.

(3) Disclaimer facts

The following repairs are not covered by the warranty.

- Failure caused by by-product of liquid or gas used
- Failure caused by misuse (including careless operation) or incorrect repair or modification
- Failure caused by falling or dropping after purchase
- Failure caused by fire, earthquake, flood, lightning or other natural disasters

Even if the warranty period is still in effect, repair service may not be provided in the following cases.

- When the kind of liquid or gas used in the product is unclear
- The product is returned with liquid or gas remaining inside and safety cannot be confirmed

Please be aware that this device is a precision instrument and the generation of excessive electrical noise, changes in liquid temperature or pressure fluctuations may result in unstable control.

This instruction manual is subject to revision without notice.

LINTEC CO., LTD.

<http://www.lintec-mfc.co.jp>

Corporate Headquarters

4-1-23 Sekinotsu, Otsu City, Shiga Pref. 520-2277, Japan
TEL. +81-(0)77-536-2210 FAX. +81-(0)77-536-2215

Tokyo Branch Office

3F Hattori Build., 4-30-14 Yotsuya Shinjyuku-ku Tokyo 160-0004, Japan
TEL. +81-(0)3-5366-2801 FAX. +81-(0)3-3341-3513