

Mass Flow Controller Instruction Manual

MC-3100/3200L Series

Safety Precautions

⚠ WARNING Incorrect handling may cause death or injury

- Before connecting the fittings, check that no damage or defects are found on the fittings. Make connections properly and make sure that a leak test is conducted before actual operation to prevent fluid from leaking into the atmosphere (Hereafter, the measured fluid is called "gas" or "fluid").
- DO NOT apply any fluids corrosive to materials exposed to gas. Corrosion may cause fluid to leak into the atmosphere. Check the gas type to be used in advance.
- This device is not designed as an explosion proof structure. DO NOT use this device in a place where explosion-proof structures are required. Doing so may cause fire or explosion.

⚠ CAUTION Incorrect handling may lead to medium or slight injury or may cause damage to, or loss of, facilities or equipment

- Observe the precautions listed in the WARNING (above)
- Strictly observe the electrical specifications. Not doing so may cause fire, damage to sensors or malfunction.
- This device is not designed to be waterproof. DO NOT locate this device outdoors or in a place where it may be splashed with water. Doing so may cause fire, trouble, or malfunction of the device.
- DO NOT modify this device. It may cause fire or other problems.
- This device is not designed to handle hot swap. Please avoid attaching and removing the power supply connector and interface connector with the power switched on. Attachment and/or removal with the power on may result in failure of the device.
- While a power supply is applied to MFC, $\pm 15\text{VDC}$ must be applied simultaneously. If only $+15\text{VDC}$ or -15VDC is applied, electronic circuits will become unstable and it may cause a malfunction of MFC.
- This device is a precious device, please handle it carefully. Dropping down or handling it carelessly will cause damage. Please use assist instrument while moving or setting the device.
- Regular maintenance is recommended for steady use of this device (Recommended proofreading frequency is once a year).

1. Introduction

This manual explains basic operation of the MC-3100/3200L series (Hereafter, it is called "MFC"). Please read through this manual and other separate volumes (Digital Interface Manual, Special Function Manual, Command Chart) carefully to familiarize yourself with the features of this device.

2. Summary

The MFC is high performance mass flow controller for gas using thermal flow sensor and high response piezoelectric valve. In the MFC model, MO type and MC type are available depending on the kind of valve operation mode.

3. Features

The MFC is the following features.

- LINTEC's proprietary ambient temperature compensation type flow sensor is carried.
 - Low sensor temperature, long-time steady monitor, and few problems such as degradation of gas to be monitored.
 - The effect of ambient temperature is less because the sensor temperature is kept at the ambient temperature.
 - Steady temperature distribution of sensor and high-speed response.
- Digital computing system with microprocessor and high-resolution A/D, D/A converter is carried.
 - High functionality
 - By setting of device number (address), multiple devices can be controlled through a single interface
 - Many additional are provided as standard, e.g., totalizer function, zero adjust, ramping function
- Universal digital Interface (RS-485)
- Small dead space structure using a diaphragm valve
- Superior corrosion resistant sealing materials make maintenance easy. Metal seals (Au)
- Particle-free structure
- By using a metal case and various types of filters, steady operation can achieve even in an environment of high-frequency noise and stationary magnetic field
- Based on RoHS

4. Structure

The MFC consists of sensors, bypass, valves, and a microcomputer for signal processing. A digital PID feedback control system controls the valve action so that flow rate output from the sensor agrees with flow rate setting value.

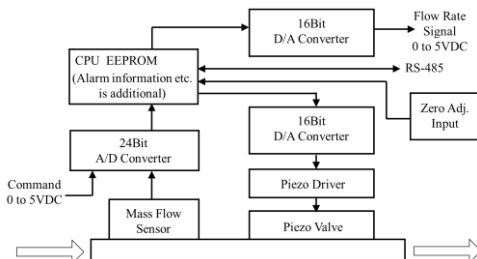

5. Specification / Dimensions

(1) Specification

Name		Mass Flow Controller		
Model		MC-3102L	MC-3202L	MC-3252L
Standard flow rate in nitrogen		5SCCM to 5SLM	~ 20SLM	~ 50SLM
Valve operation mode		Normally open valve / Normally closed valve		
Internal surface treatment		No treatment / Precision polishing (LEP)		
Minimum controllable flow rate		2%F.S.		
Analog flow rate output signal		Proportional to flow rate 0 to 5VDC		
Analog flow rate setting signal		Proportional to flow rate 0 to 5VDC		
Accuracy		100%F.S. to 25%F.S. $\pm 1.0\%$ S.P. 25%F.S. to 2%F.S. $\pm 0.2\%$ F.S.		
Repeatability		$\pm 0.2\%$ F.S.		
Response time		1 second (Typical)		
Operating differential pressure	50 to 300kPa	Normally open valve 50 to 300kPa (~10SLM) 100 to 300kPa (10 to 20SLM) Normally closed valve 100 to 300kPa (~10SLM) 200 to 300kPa (10 to 20SLM)	100 to 300kPa (~30SLM) 150 to 300kPa (~50SLM)	
Maximum operating pressure (Note1)		300kPa(G)		
Withstanding pressure		1MPa(G)		
Operating temperature & Humidity		5 to 50°C 0 to 80%RH (Condensation should be avoided)		
Temperature coefficient (Standard Temp.25°C)	Zero	$\pm 0.02\%$ F.S./°C		
	Span	$\pm 0.02\%$ F.S./°C	$\pm 0.04\%$ F.S./°C	$\pm 0.08\%$ F.S./°C
Storage temperature & Humidity		0 to 60°C 0 to 80%RH (Condensation should be avoided)		
Leak integrity		Less than 1×10^{-11} Pa · m ³ /sec (He)		
Mounting direction		Free		
Wetted materials		Stainless steel 316L, PCTFE, Au		
Seal Materials		Au		
Actuator		Piezoelectric actuator		
Fittings		6.35VCR (106, 124)	6.35UJR (106, 124)	
		1.125W-Seal (79.8mm, 92mm)	1.5W-Seal (79.8mm, 92mm)	
Power supply		$+15\text{V DC} \pm 3\%$: 100mA $-15\text{VDC} \pm 3\%$: 50mA		
Digital interface		RS-485 (2-wire)		
Weight		Approx. 1kg		

Note1) There is a possibility that the gas does not flow in case of the gas pressure of more than 490kPa was used on the MC-3252L- MO /NO.

(2) Dimensions

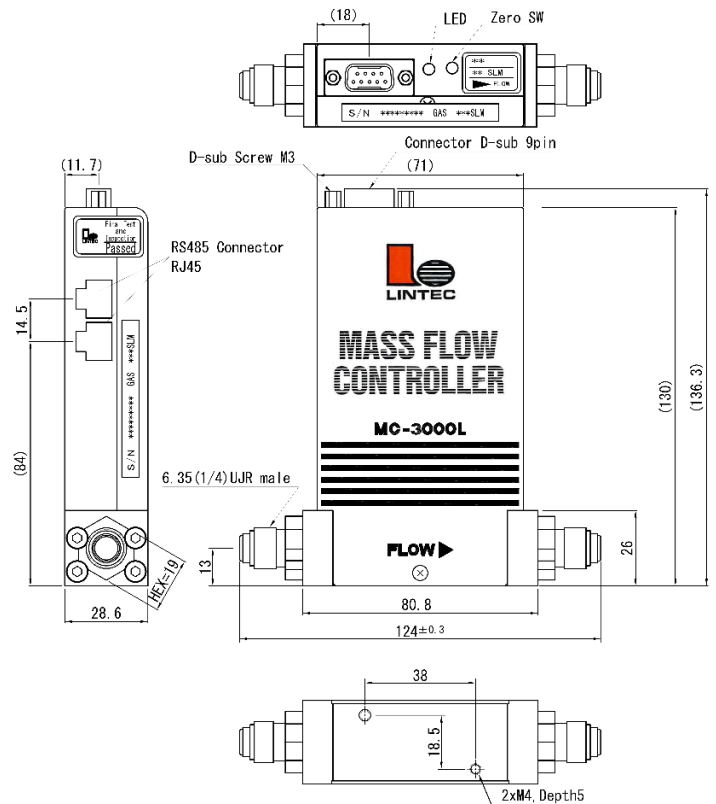

6. Ordering information

MC-3102L - MO - 4JR1 AA0A0 - dd - ee - ff
 [1] [2] [3] [4] [5] [6] [7]

[1] Series model

MC: Mass Flow Controller Series
 MC-3102L, MC-3202L, MC-3252L

[2] Valve mode

NO: Normally open (No treatment), MO: Normally open (LEP)
 NC: Normally close (No treatment), MC: Normally close (LEP)

[3] Fitting

4JR1:6.35UJR106, 4JR2:6.35UJR124, 4VR1:6.35VCR106, 4VR2:6.35VCR124, 4SWL:6.35SWL
 SPW1: Surface mount 1.5W-Seal 79.8mm, SPW2: 1.5W-Seal 92mm
 SPW3: Surface mount 1.125W-Seal 79.8mm, SPW4: Surface mount 1.125W-Seal 92mm
 ※ Please consult for more information.

[4] Optional

B: Applied to liquefied gas, D: Medium temperature specifications (45 to 55 °C)
 E: Small Range Control (1 to 4SCCM F.S. in nitrogen)
 G: Wide Range specifications (Control range 0.5 to 100 %F.S.)
 J: Valve is closed at below 2% setting
 ※ Default setting is labeled "AA0A0". Please consult for more information.

[5] Gas type

[6] Full scale flow rate

[7] Flow rate unit SCCM (0 °C standard), SLM (0 °C standard)

7. Connection

(1) Analog interface connector

Mounted connector : D-Sub 9 pin(male)

Pair connector : D-Sub 9 pin(female) (Fixed size of screw : M3)

Pin No.	Single name	Function
1	Valve on-off input (Note2)	+15VDC: OPEN, -15VDC: CLOSE
2	Flow rate output signal 0 to 5VDC	Flow rate output voltage plus side 0 to 5VDC
3	Power supply input +15VDC±3%	Power supply (plus) 100mA
4	Power supply COMMON (Note3)	COMMON ±15VDC
5	Power supply input -15VDC±3%	Power supply (minus) 50mA
6	Flow rate setting signal 0 to 5VDC (Note2)	Flow rate setting voltage plus side 0 to 5VDC
7	Flow rate output COMMON (Note3)	Flow rate output voltage COMMON
8	Flow rate setting COMMON (Note3)	Flow rate setting voltage COMMON
9	N.C.	N.C.

Note2) Input impedance of flow rate setting signal is 100kΩ. Valve override impedance is 100kΩ.

Note3) Pin No.4,7,8 are connected internally.

Wiring should be done as shown below in order to remove the effect of potential difference among the COMMON.

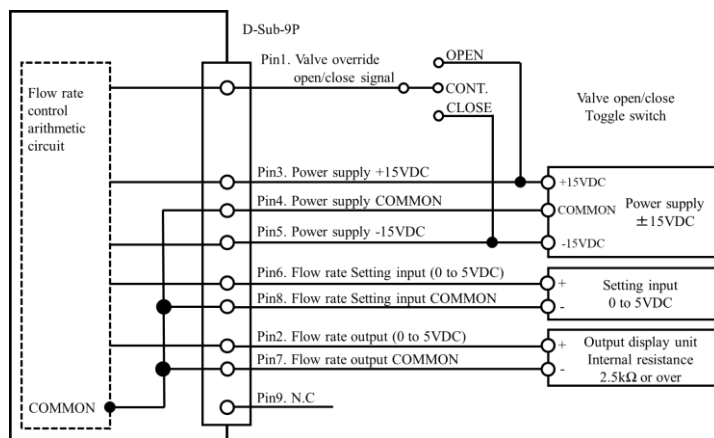

Do not connect. Flow rate setting signal COMMON[8], Flow rate output signal COMMON[7], and Power supply COMMON[4] in the power supply unit

(2) Digital interface connector

Mounted connector : RJ-45 Modular jack

Pair connector : RJ-45 Modular plug

Pin No.	Signal name	Function
1	Signal COMMON	RS-485 Signal COMMON
2	Signal COMMON	RS-485 Signal COMMON
3	N.C.	N.C.
4	Signal [- Txd / Rxd]	RS-485 2-wire system transmitter, receiver minus signal
5	Signal [+Txd / Rxd]	RS-485 2-wire system transmitter, receiver plus signal
6	N.C.	N.C.
7	N.C.	N.C.
8	N.C.	N.C.

8. Alarm functions

This MFC features two alarm modes: alarm A and alarm B. Using a digital interface, alarm output of the digital connector or LED indicator located on top of the MFC housing can monitor the alarm status. As alarm settings can only be changed using digital communication, please carry out necessary changes using this method. For details, please refer to the Interface Instruction Manual.

Alarm	Set off	LED indicator
A	Setting value≠ flow rate output	Continuous Red
	Flow totalizer Alarm level 2	
	Power supply voltage (+15VDC) drop	Off
B	Voltage of valve control change	Red (every 0.5sec flashing)
	Abnormal zero offset (Note 4)	
	Flow totalizer Alarm level 1	
Other	Command error	Continuous Red (every 0.5sec flashing)
Normal	-	Green (every 1sec flashing)

9. Software switch (factory shipped value)

This MFC is provided with a software switch for operation mode setting. Before operation, input the necessary data for various functions by using the digital interface. Details of the functions are described in the special function manual.

Software switch	Available values	Function	Default
Device number	00 to 99	MFC No. Registration	00
Alarm A range	0 to 99 [%]	Setting Alarm A range	5%
Alarm B range	0 to 99 [%]	Setting of Alarm B range	20%
Alarm timer	0 to 99 [seconds]	Setting of Alarm timer	5 seconds
Alarm A output	Enable / Disable	Setting of Alarm A output	Enable
Alarm B output	Enable / Disable	Setting of Alarm B output	Disable (Note 4)
Operation mode	Analog / Digital	Switching of Analog/digital	Analog
Power on mode	Analog / Preset	Switching of Operation mode in power turning on	Analog
Valve control	C / O / H / S	Close / Open / Hold / Servo	Servo
Control speed	FAST / SLOW	Switching of Response speed	FAST
Control mode	2%Close/2%Hold/ Normal	Control mode switching (at flow rate setting <2%) 2%Close: Valve Close 2%Hold: 2% Control Normal: Normal Control	Normal
Conversion factor	0.6666 to 1.500	Conversion factor setting	1.0000
Communication protocol	9600 to 38400bps	Baud rate	9600bps
	8bit / 7bit	Character length	7bit
	Odd/Even/ None	Parity	None
	1bit / 2bit	Stop bit	2bit

Note4) Zero adjustment error alarms regardless of the "Enable" / "Disable" of the alarm.

If a zero set input of longer than 5seconds is input the Baud rate will be set to 9600bps and other communication protocols will be returned to initial value (factory shipped value).

10. Operation

(1) Procedure

- This product is packed in a clean room before shipment. Please break the seals in a clean room after taking it out of its box.
- Check the gas type and flow rate, and check the direction of the gas flow and the MFC before installation.
- Check for gas leaks from the tubing with a helium (He) leak detector.
- Connect the interface connectors according to the Connector table.
- Power requirements are +15VDC:100mA and -15VDC: 50mA. Check the voltage, polarity, and capacitance of the power supply voltage.
- Power of ±15VDC must be applied to the product at the same time, or it may cause malfunction.
- Turn on power supply and let the equipment warm up for at least 5 minutes (Recommended time: 30min).
- Adjust the zero point by pressing the zero-adjustment switch located on the top of the MFC. Before zero-point adjustment, check that gas is not being supplied and the device was warmed up for 30 minutes or more in order to ensure sensor stability.
- Input the flow rate setting signal and supply gas with required differential pressure to the MFC. The MFC will begin to control the gas flow in proportion to the preset voltage. Full-scale voltage is 5VDC. Maximum input voltage is ±15.5VDC.
- When the output flow rate signal is used, the tolerance voltage of the external device should be more than ±15.5VDC. When it's connected the output valve may be within the range of the maximum voltage ±15.5VDC.
- Complete shut-off cannot be achieved with the gas mass flow controller. If complete shut-off is desired, a shut-off valve should be installed.
- When a highly reactive gas is used, thoroughly purge all foreign matter from the tubing and the MFC before operation.
- When contaminated gas is used, install a filter at the equipment inlet.
- Use the MFC within the range of the operating temperature (5 to 50°C), and keep it at the same temperature with the gas. If used in any environment that does not meet the above-mentioned requirements, the flow rate cannot be measured accurately and the device may fail.
- Do not switch the power supply on and off within one second. It may cause failure.

(2) Valve control signal

The MC features a forced valve open/close input function.

The connector pin No.1 is used to input the internal valve open/close signal.

By inputting this signal, a forced opening/closing of the internal valve can be performed without depending on the value of the flow rate preset signal.

When +15VDC is input: fully open

When -15VDC is input: fully closed

(3) Conversion factor

The MFC is preset based on the kind of gas and the flow rate. If a gas that is not specified is supplied, the controlled flow rate may be different from the actual flow rate. This difference is called a conversion factor, and is normally represented by a ratio with N₂. When gas B is fed into the MFC, which was calibrated with gas A, the controlled flow rate is shown below.

$$\text{Flow rate of Gas B} = \frac{\text{Conversion factor of Gas B}}{\text{Conversion factor of Gas A}} \times \text{Flow rate put value}$$

The accuracy of this value may be decreased if the character of the gas is greatly different. Also, the value of the MFC has been adjusted based on the viscosity and density of the gas, therefore if a gas other than the calibration gas is applied, the operating pressure range may be altered. The conversion factor can be set at any desired value, with an operating range of 0.6666 to 1.5000. If the conversion factor value exceeds this range, the operation of the MFC become unstable. The accuracy is different from the standard specifications of the MFC, when the conversion factor is changed.

(4) Digital interface

The MFC features the RS-485 serial digital interfaces. Many special functions can be employed using the digital interfaces. Please refer to other manuals (Digital Interface Manual, Special Function Manual, Command Chart).

11. Product warranty

(1) Period

This product is guaranteed for a period of 1 year from date of shipment. Defects are repaired according to the following regulations.

(2) Scope

Warranty coverage is restricted to this product only. Any other damage caused by this product is not covered.

(3) The following repairs are not covered by the warranty:

- 1) Failure caused by by-product of fluid used
- 2) Failure caused by misuse (including careless operation) or incorrect repair or modification
- 3) Failure caused by dropping after purchasing
- 4) Failure caused by a natural disasters

Even if the warranty period is still in effect, the following items may not be repaired.

- 1) When the kind of liquid or gas used in the product is unclear
- 2) The product is returned with liquid or gas remaining inside and safety cannot be confirmed.

The MFC is a precision instrument. Control may become unstable if electric noise, temperature change of fluid, pulsation of fluid pressure etc. occurs. Please be forewarned.

This instruction manual is subject to revision without notice.

LINTEC CO., LTD.

<http://www.lintec-mfc.co.jp>

Corporate Headquarters

4-1-23 Sekinotsu, Otsu City, Shiga Pref. 520-2277, Japan

TEL. +81-(0)77-536-2210 FAX. +81-(0)77-536-2215

Tokyo Branch Office

3F Hattori Build., 4-30-14 Yotsuya Shinjyuku-ku Tokyo 160-0004, Japan

TEL. +81-(0)3-5366-2801 FAX. +81-(0)3-3341-3513